

***Spartan*** ***DX-12***  
TM

## **Desktop DNA Analyzer**

DX-12 DNA Analyzer User Manual  
Version 3.02

***Spartan***  
TM

© 2009 Spartan Bioscience Inc. All Rights Reserved.

Information in this document is subject to change without notice. Spartan Bioscience assumes no responsibility for any errors that may appear in this document. This document is believed to be complete and accurate at the time of publication. In no event shall Spartan Bioscience be liable for incidental, special, multiple, or consequential damages in connection with or arising from the use of this document.

#### **Research Use Only**

This instrument is for research use only and is not intended for clinical or diagnostic applications.

PCR and real-time PCR processes are covered by patents issued and applicable in certain countries. Spartan does not encourage or support the unauthorized or unlicensed use of PCR or real-time PCR processes. Use of this instrument is recommended for persons that either have licenses to perform PCR and real-time PCR or are not required to obtain licenses.

#### **Patents Pending**

The Spartan DX-12™ is protected by patents pending in multiple geographic areas.

#### **Trademarks**

Spartan DX-12™ is a registered trademark of Spartan Bioscience Inc. All other trademarks are the sole property of their respective owners.

01/2009

## Table of Contents

<b>Table of Contents</b> .....	<b>iii</b>
<b>General Information</b> .....	<b>1</b>
Intended Use.....	1
Contact Information.....	1
Warranty .....	1
<b>Safety and Standards Compliance</b> .....	<b>2</b>
General Instrument Safety.....	2
Symbols.....	2
<b>Electrical Safety</b> .....	<b>3</b>
<b>Chemical Safety</b> .....	<b>4</b>
Chemical Waste Hazard .....	4
Waste Disposal .....	4
<b>Biological Hazard Safety</b> .....	<b>4</b>
<b>Standards Compliance</b> .....	<b>5</b>
<b>Box Contents</b> .....	<b>6</b>
<b>Instrument Installation</b> .....	<b>7</b>
Unpacking .....	7
Instrument Contents .....	7
Operating Requirements .....	7
Installation .....	7
Decommissioning .....	8
<b>Operating Instructions</b> .....	<b>9</b>
End-point/Real Time and Melt Curve Operational Modes .....	9
Reaction Set-up .....	9
Designing a program .....	9
<b>Run Program</b> .....	<b>10</b>
Reverse Transcription .....	12
Thermal Cycling .....	12
Melt Curve.....	12
<b>Data Analysis</b> .....	<b>13</b>
Thermal Cycling .....	13
Melt Curve.....	14
<b>Creating Custom Process Files</b> .....	<b>14</b>
Custom Process Files.....	14
Setting up a custom process file.....	14
Loading a Custom Process Files onto an Instrument.....	15
<b>Editing Standard Process Files on your PC</b> .....	<b>16</b>

Standard Process Files ..... 16

Editing Standard Process Files ..... 16

Loading a Standard Process File ..... 17

**Optional Settings ..... 17**

**Troubleshooting ..... 18**

Self Tests.....18

**Cleaning and Maintenance..... 18**

Exterior.....18

**Shipping..... 18**

**Appendix A: Technical Specifications ..... 18**

## General Information

### Intended Use

The Spartan DX-12™ is designed to analyze purified nucleic acids using nucleic acid amplification techniques such as Polymerase Chain Reaction (PCR).

The Spartan DX-12™ is for research use only and is not intended for clinical or diagnostic applications.

### Contact Information

The Spartan DX-12™ was developed and is manufactured by:

Spartan Bioscience Inc.  
203-15 Grenfell Crescent  
Ottawa, ON K2G 0G3  
www.spartanbio.com

For more information: [info@spartanbio.com](mailto:info@spartanbio.com)  
For technical support: [support@spartanbio.com](mailto:support@spartanbio.com)

### Warranty

The Spartan DX-12™ is warranted to meet or exceed the stated specifications. Spartan's sole obligation and the customer's sole remedy is limited to replacement of instruments free of charge in the event the instrument fails to perform as warranted. Spartan makes no other warranty of any kind whatsoever, and SPECIFICALLY DISCLAIMS AND EXCLUDES ALL OTHER WARRANTIES OF ANY KIND OR NATURE WHATSOEVER, DIRECTLY OR INDIRECTLY, EXPRESS OR IMPLIED, INCLUDING, WITHOUT LIMITATION, AS TO THE SUITABILITY, PRODUCTIVITY, DURABILITY, FITNESS FOR A PARTICULAR PURPOSE OR USE, MERCHANTABILITY, CONDITION, OR ANY OTHER MATTER WITH RESPECT TO SPARTAN PRODUCTS. In no event shall Spartan be liable for claims for any other damages, whether direct, incidental, foreseeable, consequential, or special (including but not limited to loss of use, revenue or profit), whether based upon warranty, contract, tort (including negligence) or strict liability arising in connection with the sale or the failure of Spartan instruments to perform in accordance with the stated specifications.

Visit [www.spartanbio.com/products/warranty\\_service/](http://www.spartanbio.com/products/warranty_service/) for complete Warranty details and Extended Warranty information.

## Safety and Standards Compliance

### General Instrument Safety

 Before operating the instrument, it is important to read this Operator's Manual thoroughly and completely. Non-observance of the operating instructions and warnings contained in this manual may entail safety hazards.

The Spartan DX-12™ must only be used by personnel trained and skillful in nucleic acid practices.

 Ensure that anyone who operates the instrument has:

- Received instructions in general laboratory safety practices and specific safety practices for the instrument.
- Read and understood all applicable Material Safety Data Sheets (MSDSs).

 There will be protection impairment if the instrument is used in a manner not specified by the manufacturer

 In case of instrument malfunction please contact the manufacturer.

### Symbols

In this Operator's Manual, symbols are used as a visual signal to point out important information.

 Important Note – This symbol is used to bring the user's attention to an important annotation.

 Warning, Risk of Danger – This symbol is used to indicate that non-compliance with the instructions or procedures may lead to physical injury, or even death, or could cause damage to the instrument.

 Biohazard - This symbol is used to indicate that certain precautions must be taken when working with potentially infectious material.

 MET International Mark with adjacent indicators 'C' and 'US'

 CE Mark (European Union)

 Manufacturer

 DC (direct current)

## Electrical Safety

The Spartan DX-12™ is an electromechanical instrument. There is a potential danger to the user of an electrical shock or physical injury if the instrument is not used according to the instructions given in this manual. Observe all general safety precautions which apply to electrical instruments.

- The power supply cord must be inserted into a power outlet with a protective earth contact (ground).
- Unplug the power supply cord from the power outlet before cleaning the instrument.
- Do not use the instrument near water.
- The instrument should be operated only with the type of power source indicated on the marking label of the power supply.
- The instrument should be used only with the supplied power supply. If the power supply becomes inoperable, please contact Spartan Bioscience for a replacement.
- Always plug the power supply into the instrument, and then plug the power supply into the power outlet.
- Do not allow anything to rest on the power cord. Do not install the instrument where the cord may be walked upon.
- To reduce the risk of electrical shock, do not disassemble the instrument. Refer servicing to Spartan Bioscience authorized service personnel.
- Do not overload power outlets as this can result in risks of fire or electrical shock.
- Unplug the power supply cord from the power outlet and refer to Spartan Bioscience authorized service personnel if one or more of the following conditions exist:
  - The power supply cord or plug is damaged or frayed.
  - If liquid has been spilled onto the instrument.
  - If the instrument has been exposed to water.
  - If the instrument does not operate normally by following the operating instructions.
- Slots in the front and back of the instrument are provided for ventilation. To protect the unit from overheating, these openings **must not** be blocked. Keep an unobstructed space of at least 30 cm (1 foot) in front and behind the instrument.

## Chemical Safety



Before handling any chemicals, refer to the MSDS provided by the manufacturer, and observe all relevant precautions.

### Chemical Waste Hazard



Wastes created during use of the instrument are potentially hazardous and can cause injury, illness, or death. Refer to MSDS and local regulations for handling, storage, and disposal of waste.

### Waste Disposal



Wear appropriate eyewear, clothing, and gloves when handling reagent and waste containers. Store, transport, and dispose of waste according to all local, state/provincial, and/or national regulations.

## Biological Hazard Safety



Although the Spartan DX-12™ works with purified nucleic acids, be aware for your own safety that all biological samples such as tissues, body fluids, and blood have the potential to transmit infectious diseases. Follow all applicable local, state/provincial, and/or national regulations. Wear appropriate protective eyewear, clothing, and gloves.

Read and follow the guidelines in these publications:

- Biosafety in Microbiological and Biomedical Laboratories (BMBL) 4th edition (<http://www.cdc.gov/OD/ohs/biosfty/bmb4/bmb4toc.htm>)
- Occupational Safety and Health Standards, Bloodborne Pathogens (29 CFR 1910.1030; [www.osha.gov](http://www.osha.gov))
- Additional information about biohazard guidelines is available at: [www.cdc.gov](http://www.cdc.gov)

If you suspect the instrument may have been exposed to any hazardous material, the instrument must be decontaminated. If you are unsure about suitability of the decontamination or cleaning agent specified in your laboratory decontamination procedure, please contact Spartan Bioscience by e-mail at [support@spartanbio.com](mailto:support@spartanbio.com) or by phone from 9am-5pm EST at +1 [877] 228-7756.

## Standards Compliance



This instrument has been tested to and complies with:

- IEC 61010-1, Safety Requirements for Electrical Equipment for Measurement, Control and Laboratory Use – Part 1: General Requirements.
- IEC 61010-2-010, Safety Requirements for Electrical Equipment for Measurement, Control and Laboratory Use – Part 2-010: Particular Requirements for Laboratory Equipment for the Heating of Materials.
- IEC 61010-2-081, Safety requirements for Electrical Equipment for Measurement, Control and Laboratory Use – Part 2-081: Particular Requirements for Automatic and Semi-automatic Laboratory Equipment for Analysis and Other Purposes.
- IEC 61010-2-101, Safety requirements for Electrical Equipment for Measurement, Control and Laboratory Use – Part 2-101: Particular Requirements for In Vitro Diagnostic (IVD) Medical Equipment.
- IECEE CB Scheme, including deviations from all participating countries.
- IEC 60825-1, Safety of Laser Products

## Box Contents

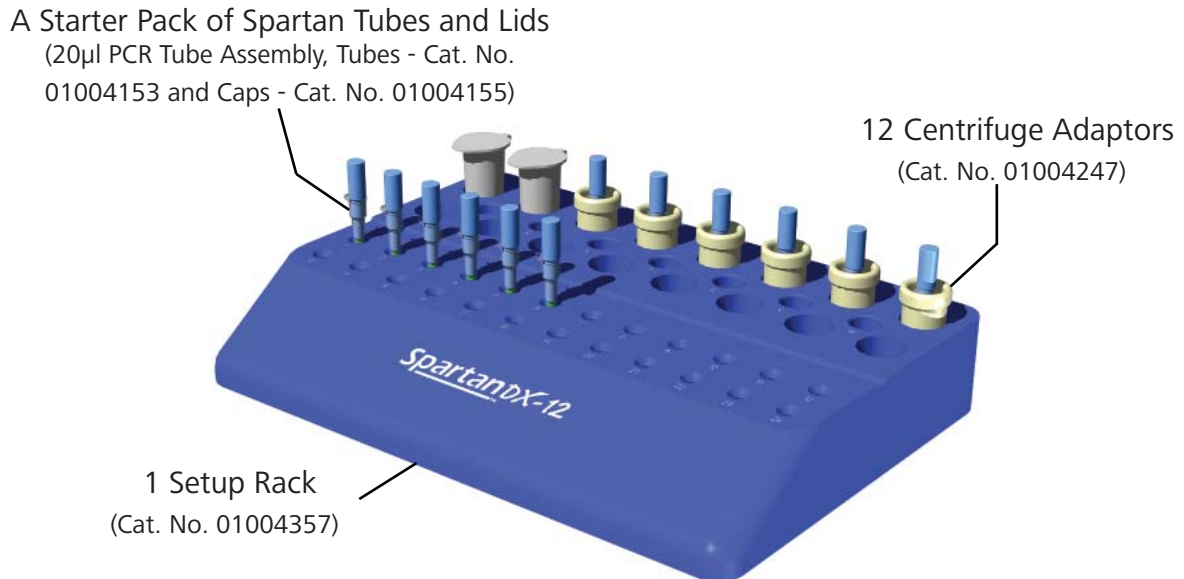
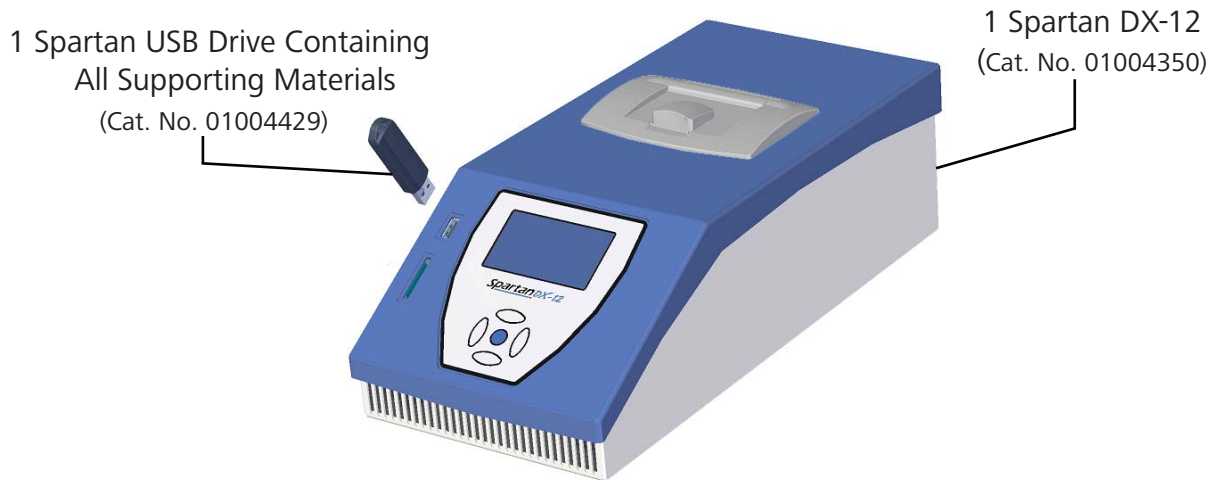

12V Power Supply and Power Cord (Cat. No. 01004381)  
Unpacking and Installation Instructions (Cat. No. 01001084)  
DX-12 DNA Analyzer User Manual (Cat. No. 01001056)  
Spartan DX-12 Quick Reference Guide (Cat. No. 01001057)  
Spartan Analyzer Software User Manual (Cat. No. 01001044)  
Release Notes (Cat. No. 01001058)

## Instrument Installation

### Unpacking

The Spartan DX-12™ is shipped in a cardboard container with molded inserts. The container should be carefully inspected for damage. Report any damage to your authorized Spartan Bioscience dealer before accepting the unit. We recommend you read the unpacking and setup instructions.

The instrument measures 17cm (W) x 36cm (L) x 12cm (H) and weighs 4.2 kg. It is easily handled by one person.

### Instrument Contents

Spartan DX-12™ Desktop DNA Analyzer (Cat. No. 01004350)

12V Power Supply and Power Cord (Cat. No. 01004381)

USB Drive Containing All Supporting Materials (Cat. No. 01004429)

12 Centrifuge Adaptors (Cat. No. 01004247)

1 Set-up rack (Cat. No. 01004357)

Starter Pack of Spartan tubes (20µl PCR Tube Assembly, Tubes - Cat. No. 01004153 and Caps - Cat. No. 01004155).



The Spartan DX-12™ should be used with manufacturer-supplied accessories only.

### Operating Requirements

This instrument is designed for indoor use only.

Operate in ambient temperature between 15 and 25°C (59 and 77°F).

Do not operate in a cold room or a refrigerated area.

Operate in ambient relative humidity of 20 to 50%.

These specifications have been calculated for altitudes between 0 and 2,000 meters.

Ensure adequate front and rear ventilation.

### Installation

1. Unpack and position the instrument on the workbench in the upright position. Allow 30 cm space in front and behind the instrument to ensure sufficient cooling of the electronic components.



Failure to provide ventilation space may impact the instrument's ability to maintain proper operating temperatures. This could negatively impact your reaction results and cause the instrument to overheat.

2. **Store original packaging in a safe location in case, at any time, the instrument should require shipping.**
3. Select a site for the instrument where:
  - Ambient temperature is maintained at 15 to 25°C. Avoid direct exposure to air conditioning, heating vents, and direct sunlight.
  - Relative humidity is 20 to 50%, non-condensing.
  - Exposure to dust and drafts is minimal.
  - There is minimal vibration to the instrument.
  - An electrical outlet is available. The power supply automatically accommodates incoming voltages between 100-240 V AC and 50-60 HZ. Use of an un-interruptible power supply (UPS) is recommended.
4. Plug the power supply into the instrument and connect the power supply to power source.
5. The instrument is now operational.

## Instrument Installation (continued)

6. Upon initial instrument running, we recommend you insert 12 empty tubes into the instrument, insert the provided UBS stick, navigate to the Options menu and initiate a report. This should take 10-15 minutes to run. Once it has been completed, please forward the results (3 files) to support@spartanbio.com so that we may verify the functionality of the unit. To set date/time:

To set date/time:

1. The first time the instrument is started, you will be prompted to set the date and time.
2. Move to the appropriate "Set Date/Time" field using the outside buttons and select using the center button.
3. Modify the fields using outside buttons and unselect by pressing center button.
4. Select "Save" using the center button to save your new date and time settings.

### Decommissioning

The Spartan DX-12™ does not require any special action to remove it from use. However, as with any electronic equipment, please follow all applicable local, state/provincial, and/or national regulations for disposal.

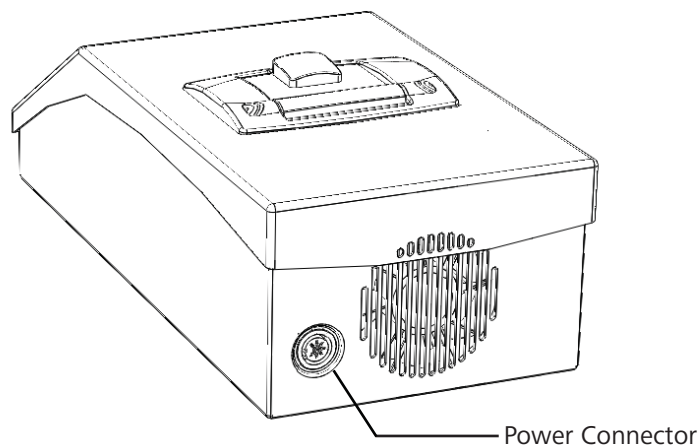
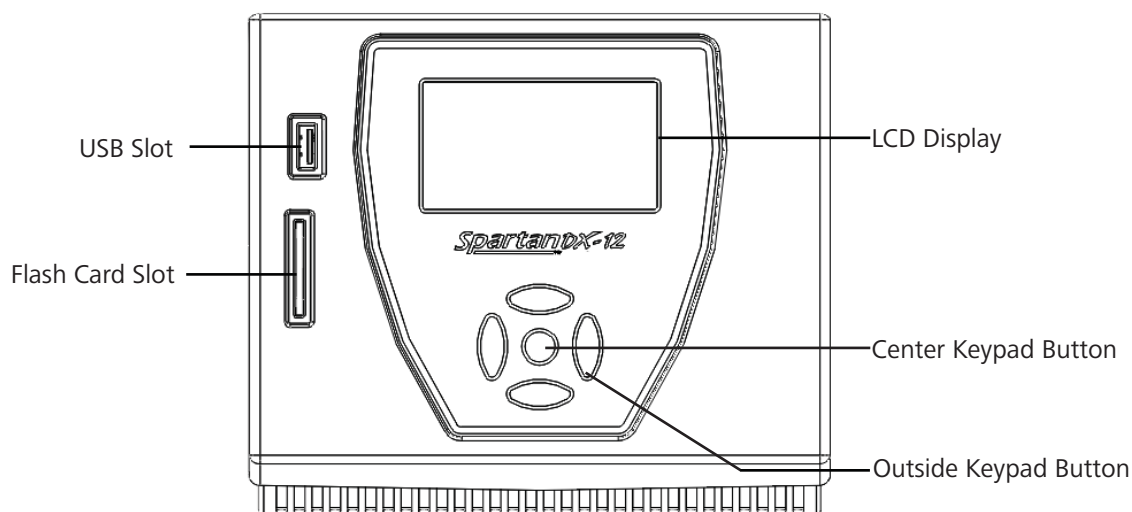

## Operating Instructions

### End-Point/Real Time and Melt Curve Operational Modes

The Spartan DX-12™ is shipped in “End-Point” operational mode. In order to operate the unit in “Real Time” or “Melt Curve” modes, these functions must be activated.

To activate “Real Time” or “Melt Curve” modes:

1. Using the keypad, select the “Options” menu on the instrument.
2. Move to “System Settings” using the outside buttons and select using the center button.
3. Once within the “System Settings” menu, “Melt Curve” or “Real Time” modes can be turned Off/On by moving to and selecting the appropriate field using the outside buttons and the center button, then toggling up and down with the outside arrow keys, pressing the center key again to register your selection.



***The first time you change the “Real Time” or “Melt Curve” operational setting, you will be prompted to “AGREE” or “DISAGREE” to a disclaimer. If you do not “AGREE” to the disclaimer, the “Real Time” or “Melt Curve” modes will remain “OFF”, and will be inaccessible. Only once the disclaimers are “AGREED” to can you access these operational modes.***

### Reaction Set-up

#### A. Thermal cycling

The Spartan DX-12™ is designed to run two- or three-temperature thermal cycling programs. A three-temperature program has three steps: denaturation, annealing, and extension. A two-temperature program combines the annealing and extension steps into a single step. Although three-temperature programs are more traditional, two-temperature programs can provide the same performance while significantly shortening run times.

Isothermal programs may also be performed on the Spartan DX-12™ by setting the denaturation, annealing, and extension steps to the same temperature.

Note that the dwell time at each temperature begins once the reaction tube reaches the specified temperature. For example, if the denaturation temperature is set at 95°C, and the denaturation dwell time is set at 10 s, the 10 s countdown begins once the reaction tube reaches 95°C. For most applications, only a few seconds of denaturation time are sufficient to denature the amplicon during thermal cycling.

#### Designing a Program

Each gene target is unique and may require optimization of the cycling program. Here are some general guidelines for determining the appropriate temperatures and dwell times for your program:

1. Design primers with matching melting temperatures ( $T_m$ ), preferably between 60-68°C, and amplicon size of < 300 base pairs (bp). For faster cycling speeds, the primers should have  $T_m$ s of 65-68°C, and amplicon size of < 150 bp.
2. Set the annealing temperature to the calculated  $T_m$ .
3. For three-temperature programs, set the extension temperature to 72°C for 10 s. For two-temperature programs, the extension temperature is combined with the annealing temperature and no separate extension time is used.
4. Set the annealing and/or extension time to 30 seconds.
5. For denaturation temperatures and times, we recommend starting with the following settings:

DNA Source	Denaturation Temp	Initial Time	Cycling Time
Human/Mammalian	95°C	2.5 min	10 s
Bacterial/Viral	95°C	1 min	10 s

## Operating Instructions (continued)

### B. Detection chemistries

The Spartan DX-12™ is a 2-channel instrument. The first channel detects green wavelengths (520-532 nm), and the second channel detects red wavelengths (620-800 nm). The detection system is compatible with standard probe chemistries such as TaqMan® probes, Scorpion probes and Molecular Beacons. It is also compatible with DNA intercalating dyes such as SYBR Green® (Life Technologies). For probe technologies, Spartan recommends the use of non-fluorescent quenchers such as BHQ-1 and BHQ-2 (Black Hole Quencher®, Biosearch Technologies). For further details, see Spartan Application Notes 005 and 012 at <http://www.spartanbio.com/application-notes/>.

For SYBR Green I dye (Invitrogen, Cat. No. S7563), we recommend a concentration of 0.4X. However concentrations in the range of 0.2-1.0X are acceptable. For further details, see Spartan Application Note 0XX at <http://www.spartanbio.com/application-notes/>.

### C. Reaction tubes

The Spartan DX-12™ is designed to work with Spartan reaction tubes (20µl PCR Tube Assembly, Tubes - Cat. No. 01004153 and Caps - Cat. No. 01004155). These tubes have been optimized for fast heating and cooling kinetics, and must be used to perform PCR on the Spartan DX-12.

Spartan reaction tubes are designed to be loaded directly with a pipette tip. To load tubes, insert loaded pipette tip to the bottom of the tube, and slowly release the liquid while raising the pipette, ensuring the tip of the pipette is kept at the surface of the liquid. This should release the liquid evenly into the tube without creating any bubbles.

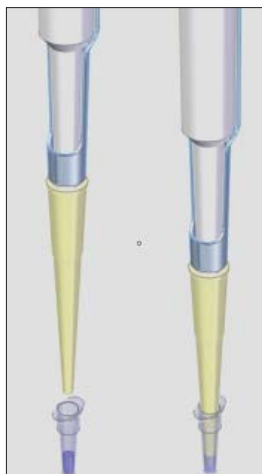

### D. Reaction volumes

Spartan reaction tubes have a maximum void volume of 25 µl. The minimum reaction volume is 10 µl. Spartan recommends standard reaction volumes of 10-20 µl.

## Run Program

### A. Warming Up and Turning Off

1. Plug in the Spartan DX-12™.
2. There is no power switch on the Spartan DX-12™. Turn on the instrument by pressing any key on the keypad, the welcome screen will appear.
3. Once the instrument is turned on, and you enter into the setup window, it will take about 10 minutes to warm up and equilibrate to room temperature.
4. To manually turn off the instrument, select "Off" from the Main Menu. When the instrument is turned "Off" all features of the instrument including fans and heaters are turned off. However, the instrument

## Run Program (continued)

is effectively in "sleep mode" and can be turned back on by pressing any button.

5. After 30 min of inactivity, the display screen will turn off. After a default time of 4 hours of inactivity, the instrument will turn "Off". This auto-shut off time can be changed through the "Options" menu, under "System settings".
6. To ensure that there is no power going to the instrument, unplug the power cord.

### B. Selecting a Program

1. Use the left and right outside keypad buttons on the keypad to move to the "File" menu. Press the center button to select this menu.
2. To create a New Program, use the outside keypad buttons to navigate down to the "New" menu and select it. In the program setup screen, edit the name of your new program by pressing the center button. Use the up and down outside keypad buttons to adjust the characters, and use the left and right outside keypad buttons to move from one character to the next. When you are finished, press the center keypad button to accept the new program name.
3. To open an Existing Program, use the outside keypad buttons to navigate down to the "Open" menu and select it. Use the up and down arrows to move between programs in the program list. Programs will be displayed in numeric, then alphabetical order. Select a program by pressing the center button. Open the program by selecting "Open" from the options on the bottom of the screen. At any time, you may select a program using the center button, and use the outside keypad buttons to move between the "Open", "Delete", and "Cancel" options at the bottom of the screen.

### C. Setting Up a Program

1. After you have created a New Program, or have opened an Existing Program, the Program Setup Screen allows you to specify settings for the Reverse Transcription, Thermal Cycling, and Melt Curve steps in your program.
2. Use the outside keypad buttons to navigate between the program steps. Select "On" or "Off" to toggle the appropriate steps. Note that the instrument will perform the steps in the following order: Reverse Transcription → Thermal Cycling → Melt Curve. Steps set to "Off" will not be performed.
3. To save modifications to your program, select the "Save" option at the bottom of the screen. If you modify any of the three components of a program and run it without saving, the program will run as entered, but the the changes will be lost at the end of the run.

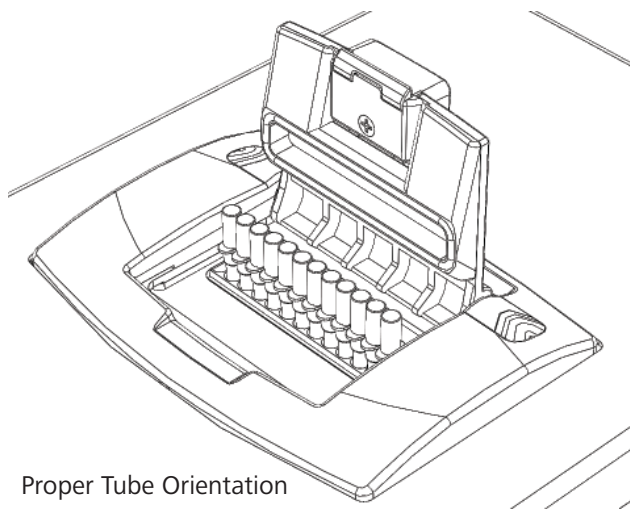

## Run Program (continued)

### Reverse Transcription

1. To modify the Reverse Transcription temperatures and dwell times, use the outside keypad buttons to navigate to "Reverse Transcription" and select it using the center button.
2. In the Reverse Transcription Setup Screen, use the outside keypad buttons to navigate between the temperatures and dwell times. After using the center button to select a setting to change, use the up and down outside keypad buttons to change the values. Use the center button to accept the new entry.
3. Step #1 specifies the Reverse Transcription synthesis conditions, and Step #2 specifies the Reverse Transcription denaturation conditions. Step #2 of the Reverse Transcription program, and Step #0 of the Thermal Cycling program are performed sequentially when both programs are selected. This should be kept in mind when setting up a program that involves a Reverse Transcription step.
4. When you are finished adjusting the values, navigate to the bottom of the screen and select "Ok".
5. To cancel your modifications, navigate to the bottom of the screen and select "Cancel".

### Thermal Cycling

1. To modify the Thermal Cycling temperatures and dwell times, use the outside keypad buttons to navigate to "Thermal Cycling" and select it using the center button.
2. In the Thermal Cycling Setup Screen, use the outside keypad buttons to navigate between the temperatures, dwell times, and cycle number. After selecting a setting to change, use the up and down outside keypad buttons to change the values. Use the center button to accept the new entry.
3. Step #0 specifies the initial denaturation conditions. During the cycling phase of the program, Steps #1, 2, and 3 specify the denaturation, annealing, and extension conditions, respectively.
4. When you are finished adjusting the values, navigate to the bottom of the screen and select "Ok" by pressing the center button.
5. To cancel your modifications, navigate to the bottom of the screen and select "Cancel".
6. By default Thermal Cycling is set to "3-Temp" thermal cycling conditions. To switch between two-temperature and three-temperature programs, toggle the "2-Temp" or "3-Temp" option at the bottom of the screen by selecting it with the center button.

### Melt Curve

1. To modify the Melt Curve temperatures and dwell times, use the outside keypad buttons to navigate to "Melt Curve" and select it using the center button.
2. In the Melt Curve Setup Screen, use the outside keypad buttons to navigate between the temperatures and dwell times. After selecting a setting to change, use the up and down outside keypad buttons to change the values.
3. Step #1 specifies the initial denaturation conditions. Step #2 specifies the starting temperature for the melt curve. Step #3 specifies the end temperature for a single-step melt curve. Step #4 specifies the end temperature for a multi-step melt curve. "°C/step" specifies the frequency of data acquisition. The minimum and maximum increments are 0.1°C/step and 1.0°C/step, respectively.
4. When you are finished adjusting the values, navigate to the bottom of the screen and select "Ok".
5. To cancel your modifications, navigate to the bottom of the screen and select "Cancel".
6. By default, the Melt Curve program is set to "Single-Step". A Single-Step program uses the same temperature increment from the starting to end temperatures. To switch between single-step and multi-step programs, toggle the "Single-Step" to "Multi-Step" option at the bottom of the screen by selecting it. A Multi-Step program allows you to set two different temperature increments between the

## Run Program (continued)

starting and end temperatures. This feature is useful if you want higher resolution for a specific region of the curve, but want the overall run-time to be short.

### D. Running a Program

1. Insert Spartan reaction tubes into the instrument. Ensure that the tubes are properly nested in each well. **Do not force the tubes down into the wells.** Close the instrument lid.
2. From the Program Setup Screen, select the "Run" option from the bottom of the screen.
3. While the program is running, you may increase the cycle number at any time by navigating to the cycle number denominator on the screen with the outside keypad, pushing the center button to select it, and the up and down arrow key to make the changes, pressing the center button again to implement the changes.
4. While the program is running, you may also select "Stop" at any time. Note that the program is only stopped after you select "Yes" to confirm stopping the program. When a program is stopped, all data accumulated to that point has been saved and is available via the "Save Last Run" feature in the "Options" menu. If a Flash Card (2 GB or less), or USB drive is present in the unit during the run, the data will also be automatically written to the drive(s).

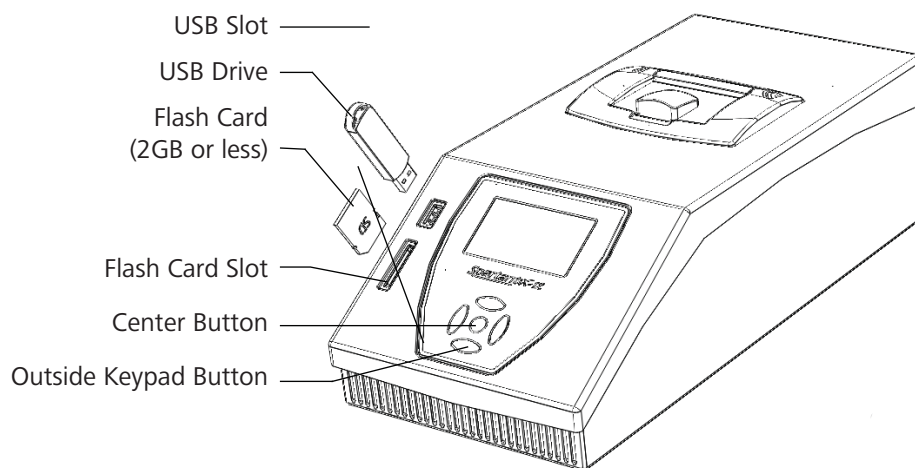

## Data Analysis

### Thermal Cycling

1. During a Thermal Cycling program, the fluorescence intensity of each well is measured after the first and last cycles. You may change from End-point detection to Real-time detection in the "Options" menu by turning on "Real-time mode". You must agree to the disclaimer before Real-time mode will be turned on.
2. At the end of a Thermal Cycling program, you may view the fluorescence results on the instrument's LCD screen. Fluorescence values are displayed on a scale from 1 to 999. Display value = (fluorescence last cycle - (minimum fluorescence+1))/2000 (rounded to the nearest whole number) If the result is <01, display "00".
3. When in "Real-Time" mode, data acquisition occurs following the Annealing/Extension step (Step 2) during 2-Temperature PCR, and following the Extension step (Step 3), during 3-Temperature PCR.
4. Selecting "Save" at the bottom of the screen saves the results to both the Flash card (2GB or less) or

## Data Analysis (continued)

the USB drives.

5. To graph the results, remove the Flash card or USB drive from the instrument and insert it into the corresponding port of a personal computer (PC).
6. Data is stored as a ".txt" file on the Flash card or USB drive. The file will be saved with the following naming convention: AAAAAAA\_UUUU\_DDMM\_RR.txt, where AAAAAA is the program name, UUUU is the unit ID number, DDMM are day and month, and RR is run of the day. This data is encrypted and can only be graphed using Spartan Analyzer software that is supplied with the instrument.



***This data can ONLY be graphed using Spartan Analyzer software that is supplied with the instrument.***

7. The User Manual for the Spartan Analyzer software is available for download at: <http://www.spartanbio.com/products/spartan-dx-12/manuals/>

### Melt Curve

1. During a Melt Curve program, the fluorescence intensity of each well is measured after each temperature increment.
2. At the end of a Melt Curve program, select "Save" at the bottom of the screen to save the results to both the Flash card and USB drives in the instrument.
3. To graph the results, remove the Flash card or USB drive from the instrument, and insert it into the corresponding port of a PC.
4. Melt curve data is stored in the same file as the Thermal Cycling data. This data may also be graphed using Spartan Analyzer software.
5. The User Manual for the Spartan Analyzer software is available for download at: <http://www.spartanbio.com/products/spartan-dx-12/manuals/>

## Creating Custom Process Files

### Custom Process Files

Although the Spartan DX-12™ comes with pre-set process files, it also offers the flexibility of creating custom process files, allowing the user to create a more complex thermal profile than that allowed through the graphical user interface (GUI). Examples of custom process files can be found on the USB key shipped with the instrument.

### Setting up a custom process file

1. Custom Process Files can be setup using spreadsheet programs such as "Microsoft Excel®", but must be saved and loaded as tab delimited text (.txt) files.
2. Custom Process Files are setup up in 5 columns, as seen in a basic example in the the table below (more detailed descriptions of each column follows in the next section):
  - The first row/header of the Custom Process File MUST be formatted as in the example below (#CUSTOM\_PROCESS), for the file to be recognized by the instrument.
  - After the header row, a "#" in front of a row represents a comment. Rows with "#" in front will be ignored by the instrument, and can be used to keep notes.
  - Custom process files are setup in to two types of thermal profiles, "Set" or "Ramp".

## Creating Custom Process Files (continued)

# CUSTOM_PROCESS				
Set	37.0	300	No	
Set	95.0	60	No	
Set	95.0	30	No	
Set	60.0	30	Yes	
Set	95.0	30	No	
Set	55.0	30	No	
Ramp	55.0	95.0	Yes	0.2

*Reverse Transcription Steps*  
(reverse transcription (37°C) and enzyme denaturation(95°C))

*2-Temp PCR (1 Step)*  
(denaturation(95°C) and annealing/extension(60°C))

*Melt Curve*  
(denaturation(95°C), annealing(60°C), and melt curve(Ramp))

During a “Set” temperature step, the instrument gets to the set temperature as quickly as possible. Set temperature steps only use the first four columns, and the columns represent:

Thermal Profile Type	Set Temp (°C)	Dwell Time (s)	Collect Data (Yes/No)
Set	37.0	300	No

*In this example, the instrument would go to a set temperature of 37°C, for 300 seconds without collecting data, then continue onto the next row in the file.*

During a “Ramp” temperature step, the instrument moves from one set temperature to the next at a ramp speed that is dependant on the melt curve step size used. Ramp temperature steps use all five columns and the columns represent:

Thermal Profile Type	Start Temp (°C)	End Temp (°C)	Collect Data (Yes/No)	Step Size (°C/Step)
Ramp	55.0	95.0	Yes	0.2

*In this example, the instrument would ramp from 55°C to 95°C in 0.2°C increments, collecting data at every increment.*

- When setting up a custom process file, “Set” temperatures, or thermal cycling, must be placed before “Ramp” temperatures or melt curves. If the program is setup otherwise, it will not run properly and the instrument may crash.
- Temperature values must be set to one decimal place, so be sure, when setting up custom process files in Microsoft Excel®, that the temperature columns are appropriately formatted before saving your file as a .txt file.
- Both “Set” and “Ramp” temperatures can be set to one decimal place in precision, and “Ramp” step sizes in increments of 0.1 between 0.1 to 2.0.
- Programs can be designed to have any number of steps, so long as the previously described rules are followed. For an example of a custom process file, with a “Reverse Transcription” step, 5 cycles of “Thermal Cycling” and a “Melt Curve” with 0.5°C/step, 0.2°C/step and 0.1°C/step step sizes, see supporting material on the USB key provided (Custom Process Example.txt).

### Loading a Custom Process File onto the Instrument

1. On the provided USB key, create a folder called “Process”, and load your newly created custom process file into this folder.
2. Mount your USB key onto the Spartan DX-12™. Using the instrument keypad, navigate to the “OPTIONS” menu, then to “Load Process File”, and select using the center button. The instrument will then locate the “Process” file on the USB key, and display the files available for upload. Select the desired file from the populated list, and “Save” using the keypad.
3. Your new custom process file is now loaded and ready for use.

## Creating Custom Process Files (continued)



**A custom Process File CANNOT be edited through the GUI. When a Custom Process File is opened on the instrument, the following message will appear on the screen: "A custom process file has been opened. This process file can be run but cannot be edited."**

## Editing Standard Process Files from your PC

### Standard Process Files

Standard Process Files are what is created through the instruments touch pad when you setup a program. These files can also be setup on a PC, using spreadsheet programs such as "Microsoft Excel®". This may be useful when sharing programs between labs (for transfer through e-mail) or when programming large numbers of files at the same time.

### Editing Standard Process Files

Standard process files are setup in the following format, which directly reflects the process gone through on the instruments user interface:

```
# Spartan test configuration file 'EXAMPLE'  
# Created: Sat Jul 25 17:29:30 2009
```

```
Reverse_Transcription_on = Off  
Rt_Temp1 = 37.0  
Rt_Temp2 = 95.0  
Rt_Time1 = 60  
Rt_Time2 = 5
```

*This section defines Reverse Transcription. In this example, the Reverse Transcription step is "Off", but if it were "On", it would go to 37°C for 60 seconds followed by 95°C for 5 seconds.*

```
Thermal_Cycling_on = On  
Tc_Temps[0] = 95.0  
Tc_Temps[1] = 95.0  
Tc_Temps[2] = 70.0  
Tc_Temps[3] = 72.0  
Tc_Times[0] = 30  
Tc_Times[1] = 10  
Tc_Times[2] = 10  
Tc_Times[3] = 0  
Tc_Cycles = 20  
Tc_Is3Temp = Off
```

*This section defines Thermal Cycling. In this example, the Thermal Cycling step is "On", and the program is set as a 2-temperature PCR (Tc\_Is3Temp is "Off"). In this instance, the instrument would go to 95°C for 30 seconds followed by cycling 20 times through 95°C for 10 seconds, 70°C for 10s, ignoring Tc\_Temps[3] and Tc\_Times[3].*

```
Melt_curve_on = Off  
Mc_Temps[0] = 95.0  
Mc_Temps[1] = 55.0  
Mc_Temps[2] = 55.0  
Mc_Temps[3] = 95.0  
Mc_Temps[4] = 95.0  
Mc_Times[0] = 30  
Mc_Times[1] = 30  
Mc_Times[2] = 0  
Mc_PerStep[0] = 0.50  
Mc_PerStep[1] = 0.20  
Is_Multi_Step = Off
```

*This section defines Melt Curve. In this example, the Melt Curve step is "Off", and the program is set as a single step melt curve (Is\_Multi\_Step "Off"). In this instance, if Melt Curve was "On" the instrument would go to 95°C for 30 seconds, then 55 for 30s, followed by a 0.5°C/step Melt Curve, ignoring Mc\_Temps[4], and Mc\_PerStep[1]. Mc\_Times[2] must ALWAYS be set to 0.*

- As with the "Load Process File" a "#" in front of a row represents a comment. Rows with "#" in front will be ignored by the instrument, and can be used to keep notes etc.
  - Other than rows beginning with the "#", only the portion of the row following the "=" can be changed.
  - Each row represents a field that is editable through the instruments user interface.
  - Set up a program filling it in as you would the setup on the user interface, making sure that the

## Editing Standard Process Files from your PC (continued)

appropriate thermal programs are set to “On”, and “3-Temp” (Tc\_Is3Temp), and “Multi-Step” (Is\_Multi\_Step) are setup as required. An example of the text present in a Standard Process File is shown above, see the supporting material on the USB key provided for an example of a standard process file (EXAMPLE - choose “open with” option on your PC and use either “Notepad” or “Microsoft Excel®” to view the file).



***Standard Process Files are loaded onto the instrument without file extensions. To do this, save your completed process file in .txt format. Before loading the process file onto the instrument, rename the file, removing the file extension.***

### Loading a Standard Process File onto the Instrument

1. On the provided USB key, create a folder called “Process”, and load your newly standard custom process file into this folder.
2. Mount your USB key onto the Spartan DX-12™. Using the instrument keypad, navigate to the “OPTIONS” menu, then to “Load Process File”, and select using the center button. The instrument will then locate the “Process” file on the USB key, and display the files available for upload. Select the desired file from the populated list, and “Save” using the keypad.
3. Your new process file is now loaded and ready for use.

## Optional Settings

In the “Options” menu, there are various optional settings and features:

1. Move to the appropriate “Set Date/Time” field using outside buttons and select using center button. Modify the fields using outside buttons and unselect by pressing center button. Select “Save” to save your new date and time settings. Note that it is important to set the correct date and time because a date-and-time stamp is saved with the fluorescence results for each run.
2. To re-save the results from the previous run, select “Save Last Run”. Note that the instrument will only store data from the most recent run and that these results will be over-written with every additional run.
3. To troubleshoot any problems you may experience with the instrument, select “Reports”. This will save an instrument status report to the Flash card and USB drives. The self tests will take 10-20 minutes for the instrument to perform. The resulting report can be e-mailed to Spartan Bioscience for troubleshooting.
4. Some DNA amplification assays for the Spartan DX-12™ come with pre-defined programs. These programs may be up-loaded to the instrument by saving them to Flash Card or USB under a folder named “process” and ensuring that they have a 7-digit name. These pre-defined programs can then be loaded onto the instrument by inserting the Flash Card or USB in to the instrument and selecting “Load Process File”, choosing the appropriate program, and selecting transfer. Loading a process file with the same name as an existing one will overwrite the pre-existing file. Note that process files cannot be edited through the “Open” menu.
5. In the “System Settings” menu, you have the option of turning “On” or “Off” the “Real-Time Mode” and “Melt Curve Mode” features. You may also specify the duration of time before the instrument automatically shuts off after a period of inactivity.

## Troubleshooting

If you experience problems using the Spartan DX-12™ please visit the Spartan Support page (<http://www.spartanbio.com/support/>), or contact Spartan by e-mail at [support@spartanbio.com](mailto:support@spartanbio.com), or by phone from 9am-5pm EST at +1 [877] 228-7756.

### Self Test

If you feel that the instrument is not working to your expectations, navigate to the “Options” menu, and with a Flash Card or USB connected the unit, select “Reports”. The instrument will take 10-20 minutes to export a report to the Flash Card or UBS drive. The Report can now be transferred to your PC and e-mailed to Spartan Bioscience at [support@spartanbio.com](mailto:support@spartanbio.com). If you have any questions or require help with this procedure, please contact Spartan Bioscience by e-mail at [support@spartanbio.com](mailto:support@spartanbio.com) or by phone from 9am-5pm EST at +1 [877] 228-7756.



No user-serviceable parts are inside. Do not remove covers that require tool access.

## Cleaning and Maintenance



Never clean the instrument without disconnecting the power cord.



To prevent dust and debris from falling into the machine, keep the lid closed at all times.

### Exterior

Clean outside surfaces as necessary with 70-100% ethanol or dilute bleach solutions (up to 10%).



No user-serviceable parts are inside. Do not remove covers that require tool access.



Refer servicing to Spartan Bioscience authorized service personnel.

## Shipping

For transportation or relocation of the Spartan DX-12™, use only the original packaging. If you should require packaging, please contact please contact Spartan Bioscience by e-mail at [support@spartanbio.com](mailto:support@spartanbio.com) or by phone from 9am-5pm EST at +1 [877] 228-7756.

## Appendix A: Technical Specifications

<b>Complete system</b>	
Dimensions	17(W) x 36(L) x 12(H) cm
Total weight	4.2 kg
Voltage requirements	100-240 V, 50-60 Hz
Power consumption	12VDC, 6.5A, 100W. DIN-8 connector (female)
Accessories included	Spartan DX-12™, User manual, USB Flash Drive, 12V power supply, 12 centrifuge adaptors, 1 set-up rack, starter pack of tubes, CD with Graphing Software
Warranty	1-Year Standard Warranty

<b>Optical module</b>	
Excitation source	12 white LEDs
Emission filter	Green: 520-532 nm / Red: 620-800nm
Detector	10bit CMOS Camera
Fluorescence acquisition modes	Real-time (every cycle) and end-point (first and last cycle)

<b>Thermal module</b>	
Sample capacity	12 x 25 µl Spartan PCR tubes
Temperature Precision (°C) (3 min after start reaching set temperature)	± 0.05
Temperature Accuracy (°C) (30 s after start)	± 0.5
Temperature Uniformity (°C) (30 s after start)	± 0.5
Ramp rates (°C/s)	Avg. 60-90°C: 3.0 heating, 2.5 cooling
Peak ramp rate (°C/s)	8.5
Warm-up time from ambient start	10 minutes

<b>Data output</b>	
LCD display	7.0(W) x 4.0(L) cm
Flash memory drive	Stores data in .txt format for easy graphing

<b>Environment</b>	
Operating temperature	20-25°C
Relative Humidity	20-50% noncondensing
Operating Altitude	0-2,000 meters
Operating Environment	Indoor use only
Installation Category	II
Pollution Degree	2